

BI-DIRECTIONAL KNIFE GATE VALVE XD-HP SERIES

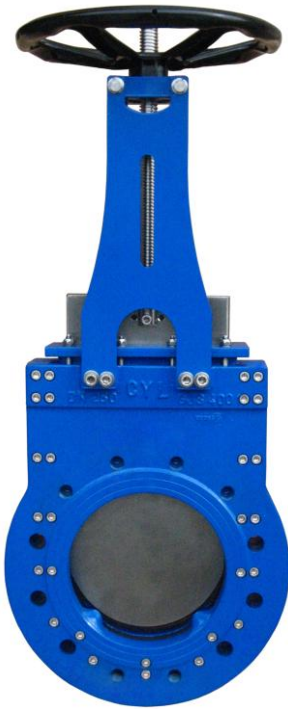

KGV XD-HP SERIES WITH
HANDWHEEL RS



KGV XD-HP SERIES WITH
HYDRAULIC ACTUATOR



KGV XD-HP SERIES WITH SPUR
GEARBOX

The XD-HP series knife gate is a bi-directional high performance valve specially designed to withstand high pressures (PN10, PN16, PN25, PN40, PN64, PN100, PN160, PN250). Resilient seated valve suitable to handle semi-solids, raw sewage, mud, dehydrated sludge and general industrial applications.

GENERAL FEATURES

- 100% tight in both directions
- Two split body arrangements
- U-seat with a steel stiff core vulcanized, fixed between the two bodies by screws.
- Adjustable external stuffing box, allowing upper sealing replacement without valve disassembling from the pipeline
- Short face-to-face dimension
- Smooth and unobstructed full flow passage, no cavity or void in body, means no clogging
- Easy drive replacement
- Self cleaning design; little maintenance required
- Proximity and limit switch mounting points



APPLICATION FIELDS

- Wastewater treatment
- Dehydrated sludge
- Power plants
- Mining
- Oil rigs
- Tunnel boring
- Etc

TECHNICAL DATA

- **Size range:**
DN-50 (2") to DN-1800 (72")
- **Working pressure:**
DN 350 to DN 600: 10 kg/cm²
DN 50 to DN600: 16 kg/cm²
DN 50 to DN600: 25 kg/cm²
DN 50 to DN600: 40 kg/cm²
(For higher pressure, please ask factory)
- **Flange ratings:**
PN10, PN16, PN25, PN40, PN64, PN100, PN160, PN250 and ANSI B16.5
(Other flange drillings under request)
- **Coating:**
RAL 5017, 150 microns epoxy coated
- **Directives:**
Pressure equipment directive 97/23/CE
DIR 2006/42/CE (MACHINES)
DIR 94/9/CE (ATEX)
Approved certificate for potable water

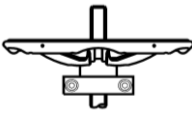
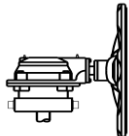
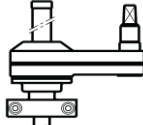
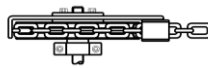
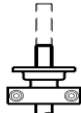
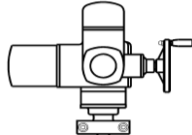
ASSEMBLY CONFIGURATION

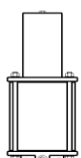
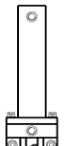
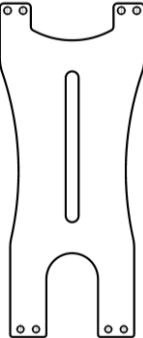
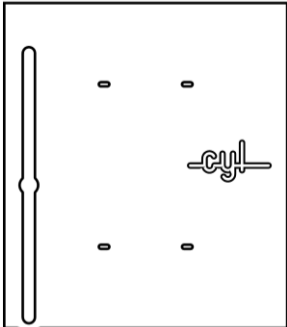
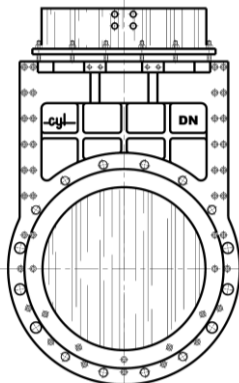
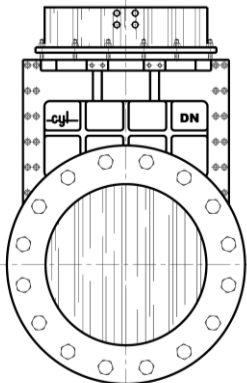
	STANDARD	OPTIONAL				
OPERATION						
	Rising stem handwheel	Gearbox	Spur gearbox	Chain Wheel		
OPERATION						
	Rising stem coupling A	Electric actuator	Double acting pneumatic actuator	Spring-return pneumatic actuator	Oil hydraulic actuator	
PLATES						
	Plates		Hand protections for automated valves			
BODY						
	Fully lugged – between flanges (Partly tapped and partly through holes)		Fully lugged valve suitable for end of line with a counter flange			
ACCESSORIES	<ul style="list-style-type: none"> - Locking device - Overriding actuator - Mechanical limit switches - Proximity limit switches - Mechanical position indicator - V-port (Aisi 316) - Deflector cone (Ni-hard) - Chest scraper (Bronze / PPS plastic) - Solenoid valve - Extended guided plates 					

MATERIAL SPECIFICATION & PART LIST

No.	DESCRIPTION	MATERIAL
001	Body	Ductile Iron (Standard) Carbon steel, CF8M-AISI 316, DUPLEX 2205, SMO254 (optional)
002	Gate	SS 316 (standard) SS 316L , SS 316TI, DUPLEX 2205, SMO 254, (optional)
007	Seat	NBR (standard) EPDM, VITON, NATURAL RUBBER
E	Packing material	PTFE+NBR, (standard) PTFE+EPDM, PURE PTFE, ARAMIDE, GRAPHITE (optional)
P	Packing gland	Ductile iron (standard) Carbon steel, CF8M-AISI 316, DUPLEX 2205, SMO254 (optional)
T	Screws and nuts	A4
071	Plates	1.0580 (standard) SS 316 (optional)
-	Stem	SS 316
-	Bearing	1.0401 (standard) SS 316 (optional)
-	Handwheel	1.0037
-	Pneumatic act.	Aluminium (standard) Steel epoxy (optional)
-	Hand-protections	1.0580 (standard) SS 316 (optional)

Figure 1. Exploded view of KGV XD-HP series fully lugged

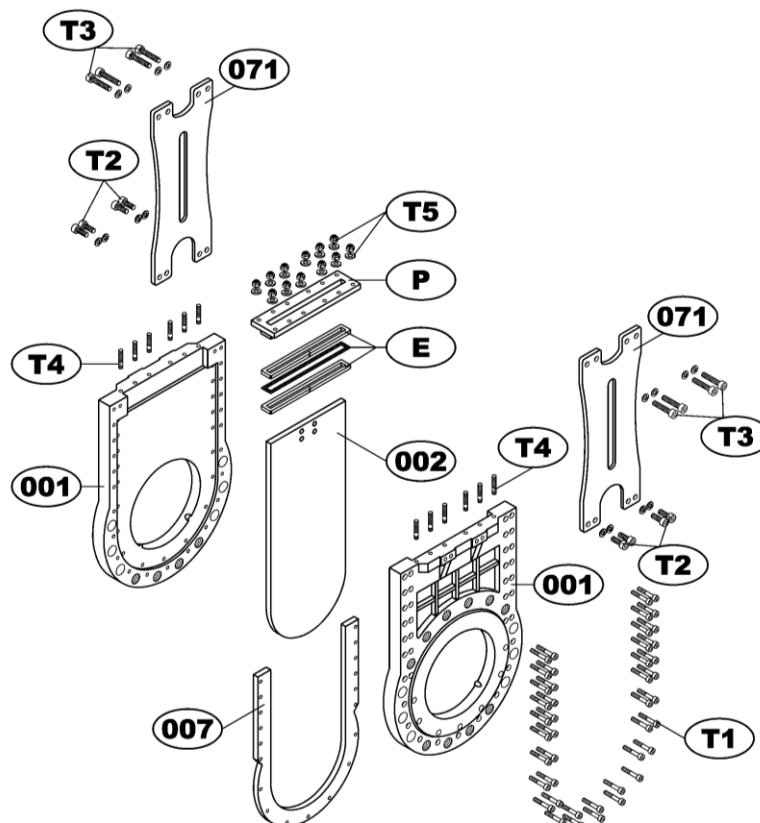

APPLICATION AND TEMPERATURE RANGE

SEAT MATERIALS			
Material	Min. temperature (°C)	Max. temperature (°C)	APPLICATIONS
NBR	-30	+80	Hydrocarbons and biogas waste
EPDM	-30	+90	Clean and chlorided water
VITON	-40	+180	Organic acids, hydrocarbons and heat resistant
NATURAL RUBBER	-10	+70	Tear and abrasion resistant
POLIURETHANE	-10	+80	Abrasive mediums/mineral handling

**More details and other sealing materials under request.*

PACKING MATERIALS			
Material	Min. temperature (°C)	Max. temperature (°C)	APPLICATIONS
COTTON-PTFE	-30	+100	Hydrocarbons
ARAMIDE	-40	+250	Bulk handling
GRAPHITE	-40	+300	Hydrocarbons, heat resistant and solids

**More details and other sealing materials under request.*

DIMENSIONAL DRAWINGS

10 BARS WORKING PRESSURE / 15 BARS TEST PRESSURE

Figure 3. KGV XD-HP series rising stem & handwheel

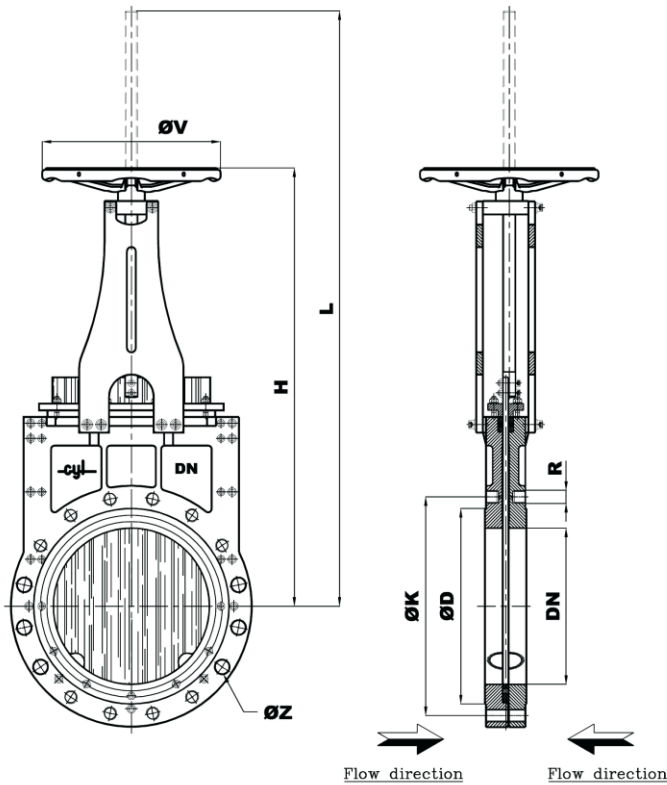

Figure 4. KGV XD-HP series rising stem with handwheel & gearbox

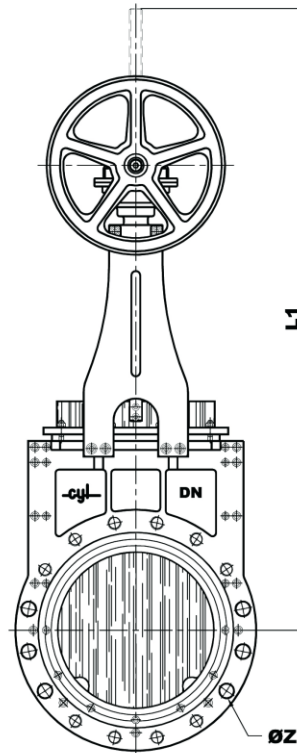
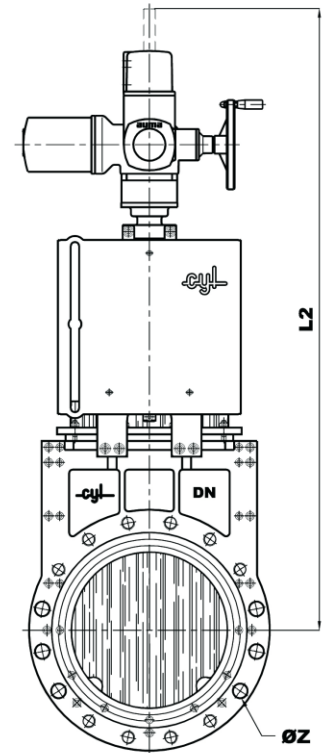

Figure 5. KGV XD-HP series rising stem with electric actuator



DN	H	L	ØV	Ø D	Ø K	R	L1	L2	Ø Z
350	982	1334	400	430	460	M-20	1393	1393	23
400	1178	1581	500	482	515	M-24	1608	1608	27
450	-	-	-	532	565	M-24	1761	1761	27
500	-	-	-	585	620	M-24	1890	1890	27
600	-	-	-	685	725	M-27	2272	2272	30

Note: flange drilling and working pressure PN10. For other flange ratings, please ask factory.

16 BARS WORKING PRESSURE / 24 BARS TEST PRESSURE

Figure 6. KGV XD-HP series rising stem & handwheel

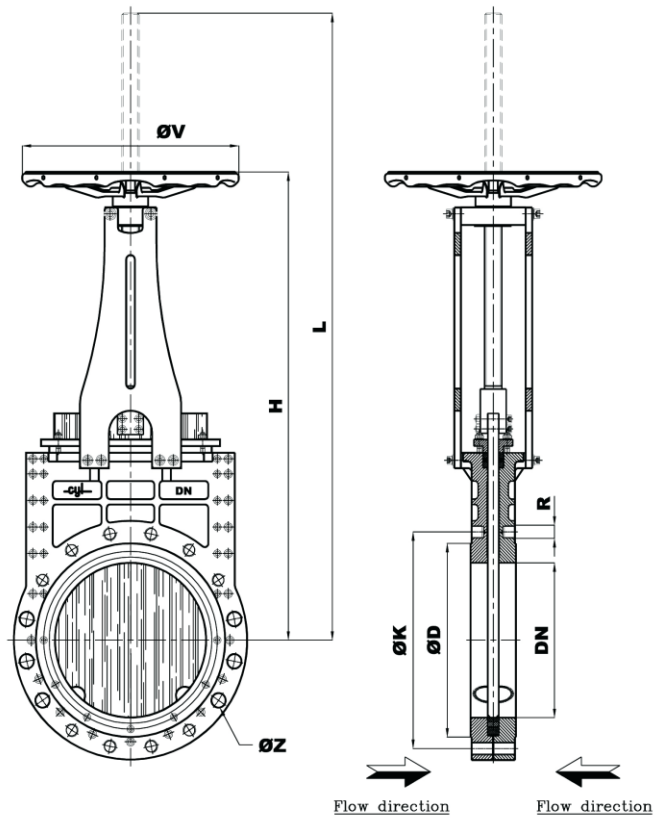

Figure 7. KGV XD-HP series rising stem with handwheel & gearbox

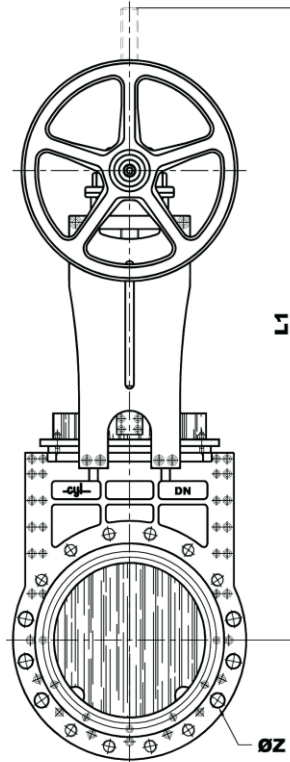
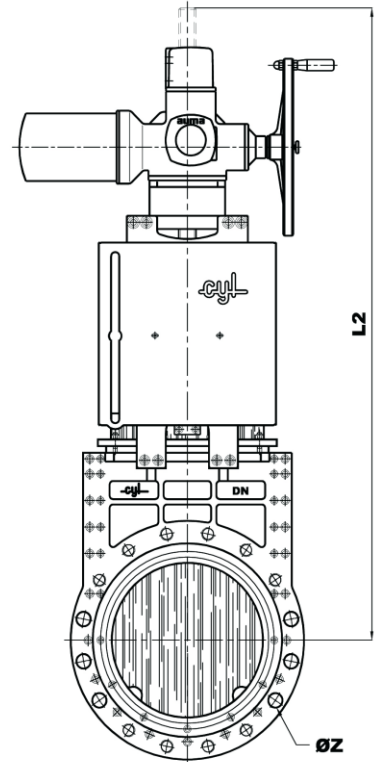

Figure 8. KGV XD-HP series rising stem with electric actuator



DN	H	L	ØV	Ø D	Ø K	R	L1	L2	Ø Z
100	422	524	225	158	180	M-16	-	757	18
125	457	584	225	185	210	M-16	-	792	18
150	567	718	300	212	240	M-20	-	894	23
200	666	868	400	268	295	M-20	-	982	23
250	818	1096	400	320	355	M-24	1139	1139	27
300	948	1238	500	378	410	M-24	1260	1260	27
350	1059	1418	500	430	470	M-24	1430	1430	27
400	1178	1581	500	490	525	M-27	1608	1608	30
450	-	-	-	550	585	M-27	1761	1761	30
500	-	-	-	585	650	M-30	1820	1820	33
600	-	-	-	685	770	M-33	2272	2272	36

Note: flange drilling and working pressure PN16. For other flange ratings, please ask factory.

25 BARS WORKING PRESSURE / 38 BARS TEST PRESSURE

Figure 9. KGV XD-HP series rising stem & handwheel

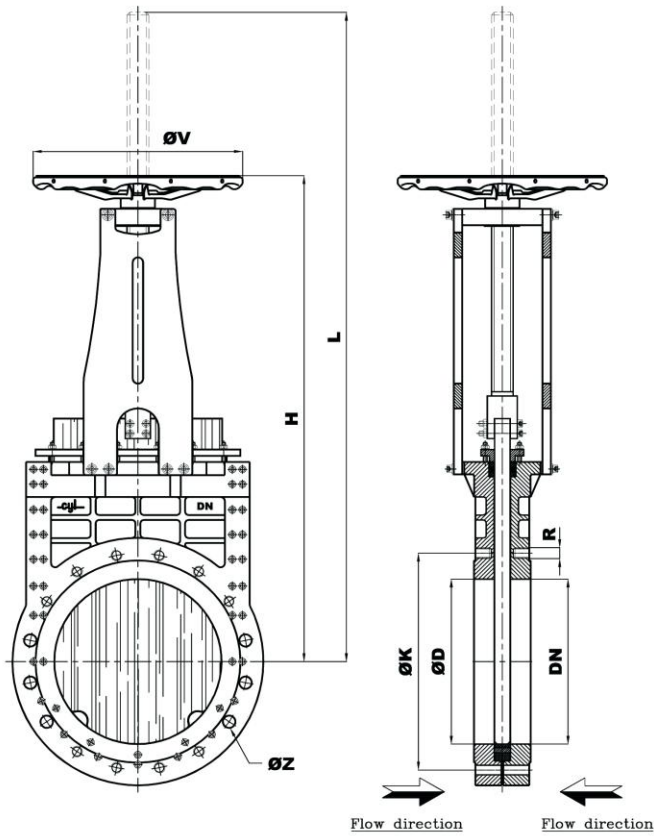

Figure 10. KGV XD-HP series rising stem with handwheel & gearbox

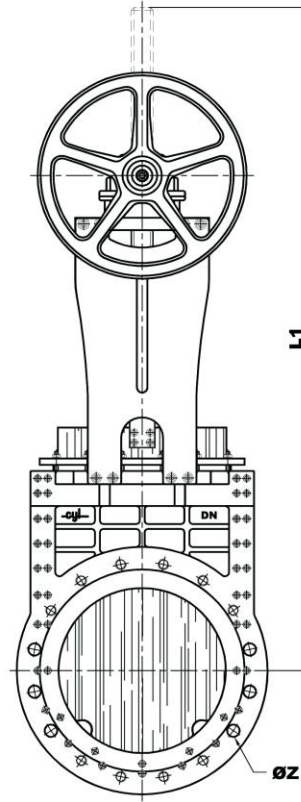
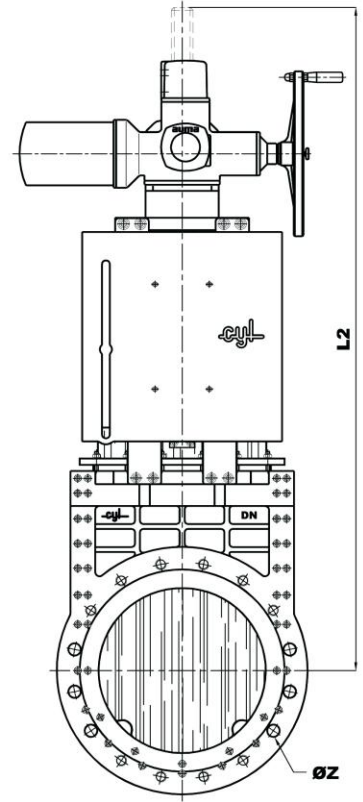

Figure 11. KGV XD-HP series rising stem with electric actuator



DN	H	L	ØV	Ø D	Ø K	R	L1	L2	Ø Z
50	320	375	225	102	125	M-16	-	658	-
65	350	412	225	122	145	M-16	-	688	18
80	367	456	225	138	160	M-16	-	702	18
100	437	540	300	158	190	M-20	-	764	23
125	476	602	300	188	220	M-24	-	803	27
150	577	739	400	212	250	M-24	788	894	27
200	666	878	400	268	310	M-24	927	982	27
250	839	1090	500	320	370	M-27	1100	1131	30
300	948	1238	500	378	430	M-27	1260	1260	30
350	1059	1418	500	438	490	M-30	1430	1430	33
400	1178	1581	500	505	550	M-33	1608	1608	36

Note: flange drilling and working pressure PN25. For other flange ratings, please ask factory.

ORDERING GUIDE

SERIES	OPERATIONS	BODY MATERIAL	DN	SEAT MATERIAL	BODY TYPE
XD-HP	V	12		NI	W
	V → Handwheel r.s	12 → Ductile iron		NI → NBR	LW → Fully Lugged (BETWEEN FLANGES)
	VR → Handwheel r.s + Bevel Gearbox	18 → Carbon steel		EP → EPDM	
	B → Iso top flange r.s.	14 → Stainless steel		VI → VITON	
	BR → Iso top flange r.s. + Bevel Gearbox	17 → Fully stainless steel		PU → POLIURETHANE	
	M → Electric actuator r.s.			NR → NATURAL RUBBER	
	MR → Electric actuator r.s. + Bevel Gearbox				
	N → D/A pneumatic actuator				
	SE → S/A pneumatic actuator				
	H → Oil hydraulic actuator				
	VCH → Chain wheel r.s.				
	VCHR → Chain wheel r.s. + Bevel Gearbox				
	CR → Square cap and spur gearbox				